

# CNB POWER

Quality Maker

## CNBPOWER® SERIES 6

# 650-670W Mono FULL BLACK

## 132 Half-Cell Layout

M12/210mm Cell

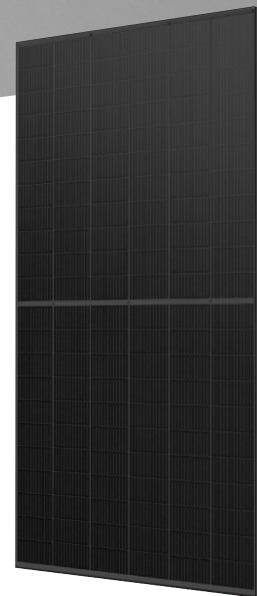

Ideal Choice For Large Scale Ground Installation  
Lower BOS & LCOE



High Density Interconnect Technology



Gallium-doped Technology



Anti-PID Low LID Performance



Less Hot Spot Shading Effects



Full Black Appearance for Aesthetic Effect

### Linear performance Warranty

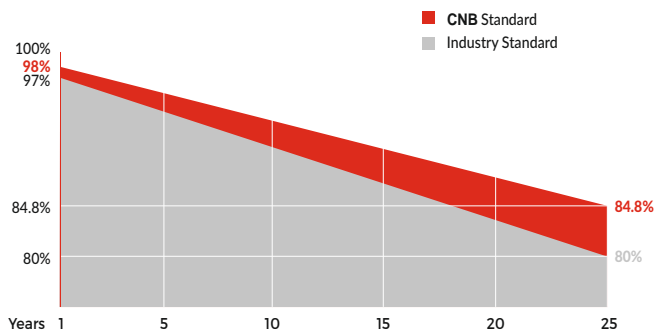

### Comprehensive Certificates

- ISO9001:2015 QMS
- ISO14001:2015 EMS
- ISO45001:2018 OHSMS
- IEC61215/IEC61730 Standard quality



MECHANICAL CHARACTERISTICS

Solar Cells	Mono
No. of Cells	132 (6x22)
Dimensions	2384 x 1303 x 35mm
Weight	34.0kg
Front Glass	3.2mm coated tempered glass
Frame	Anodized aluminium alloy
Junction Box	Ip68 rated (3 by pass diodes)
Output Cables	4.0mm <sup>2</sup> 300mm (+) / 300mm (-) Length can be customized
Connectors	Mc4 compatible
Mechanical load test	5400Pa

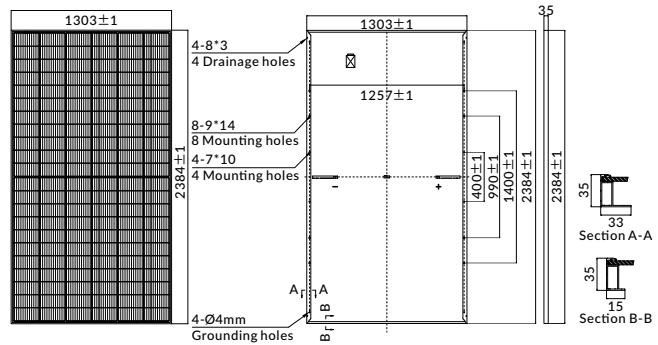

ELECTRICAL PARAMETERS

POWER CLASS	LNET-650M		LNET-655M		LNET-660M		LNET-665M		LNET-670M	
	STC	NMOT	STC	NMOT	STC	NMOT	STC	NMOT	STC	NMOT
Maximum power (Pmax)	650W	494W	655W	498W	660W	502W	665W	506W	670W	510W
Open Circuit Voltage (Voc)	45.00V	41.19V	45.12V	41.38V	45.35V	41.56V	45.54V	41.74V	45.71V	41.92V
Short Circuit Current (Isc)	18.59A	15.50A	18.66A	15.54A	18.69A	15.58A	18.73A	15.62A	18.78A	15.66A
Voltage at Maximum power (Vmpp)	37.54V	34.07V	37.71V	34.25V	37.88V	34.43V	38.04V	34.61V	38.22V	34.79V
Current Maximum Power (Impp)	17.31A	14.50A	17.37A	14.54A	17.42A	14.58A	17.48A	14.62A	17.53A	14.66A
MODULE EFFICIENCY (%)	20.92%		21.09%		21.25%		21.41%		21.57%	

STC: Irradiance 1000W/m<sup>2</sup>, cell temperature 25°C, AM1.5G    NMOT: Irradiance 800W/m<sup>2</sup>, ambient temperature 20°C, wind speed 1m/s, AM1.5G

PACKING CONFIGURATION

Container	40'HQ
Pieces per pallet	32
Pallets per container	18
Pieces per container	576

I-V CURVE

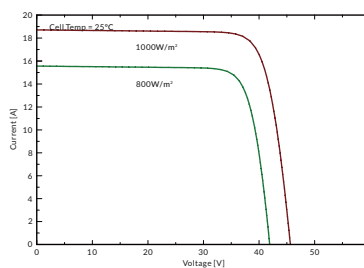

LNET-670M/I-V

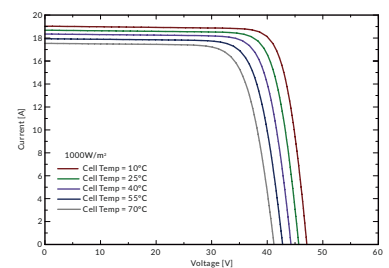

OPERATING CHARACTERISTICS

Operating Module Temperature	-40°C to +85°C
Maximum System Voltage	1500 DC (IEC)
Maximum Series Fuse Rating	30A
Power Tolerance	0/+5W

TEMPERATURE CHARACTERISTICS

Nominal Operating Temperature (NMOT)	43±2°C
Temperature Coefficient of Pmax	-0.34%/°C
Temperature Coefficient of Voc	-0.25%/°C
Temperature Coefficient of Isc	+0.04%/°C

**Note:** The specifications, data and technical characteristics provided in this data sheet are subject to changes due to continuous R&D, product innovation and improvement. CNB SOLAR reserves the right to modify the information any time without prior notice.